

無油式空氣壓縮機

Oil-less Air Compressor



往復式空壓機

Reciprocating Air Compressor

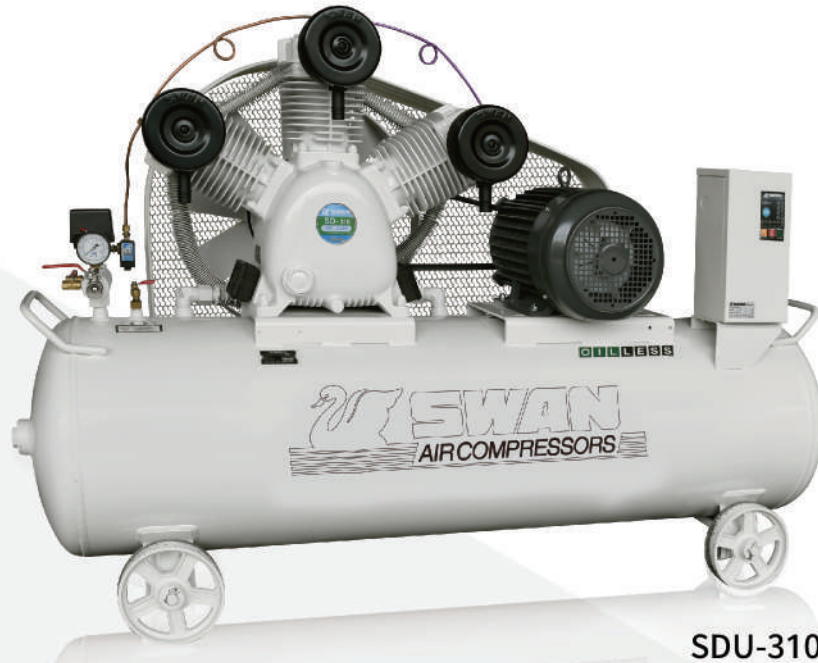

SDU-310

無油優勢

Oil-less Advantage

採用高信賴精密零組件，提供穩定的產品壽命；乾式運轉設計結構不使用潤滑油，避免油氣汙染製程設備與產品，能以更低的處理成本來達成高品質潔淨空氣需求。

High reliability precision components to provide stable product life; Dry running design structure does not use lubricant, avoiding the pollution of oil mist on equipment and products, to lower the processing cost to achieve high quality clean air demand.

Specs. 規格 Model 型式	Motor (kw/hp) 馬 達	Working Pressure (Kg/cm ² .g) 使用 壓力	F.A.D. (l/min) 實際排氣量	Tank Capacity (Liter) 儲氣桶容量	Dimension LxWxH (mm) 尺 寸	Weight (kg) 重 量
SDU-203	2.2 3	8	285	155	1480X520X950	150
SDU-205	3.7 5	8	485	240	1525X580X1200	230
SDU-307	5.5 7.5	8	730	300	1835X650X1300	250
SDU-310	7.5 10	8	885	300	1835X650X1300	250
SDU-415	11 15	8	1320	300	1835X650X1300	330

※本公司不斷研究改進，規格數據若有變更，恕不另行通知。

※如有規格外之壓力、馬力、排氣量等其他需求，歡迎您與本公司洽詢！

※Reserve the right to alter design or specifications. Due to time lag, actual specification may differ from that shown above.

※Other specific requirement about working pressure, horsepower, air delivery, etc. are available upon request.



結構 Structure

高信賴的機體組件 Highly Reliable Components

墊片 Gasket

石墨材質，耐高溫、導熱性佳、無毒環保
Graphite material, high temperature resistant, good heat conduction, non-toxic pollution, environmental friendly

進/排氣閥組 Suction/Discharge Valve Assy

高效率、壽命長
High efficiency.
Longer working life

冷卻系統 Cooling System

經平衡校正的大型散熱風扇；節省能源、不必額外的風扇馬達
Well balanced cooling fan provides sufficient cooling effects and energy-saving

曲軸 Crankshaft

堅韌材質，平衡校正、中空設計，降低運作溫度、運轉平順
High grade ductile cast iron; hollow casting design with well balanced to make running smoothly and efficiently

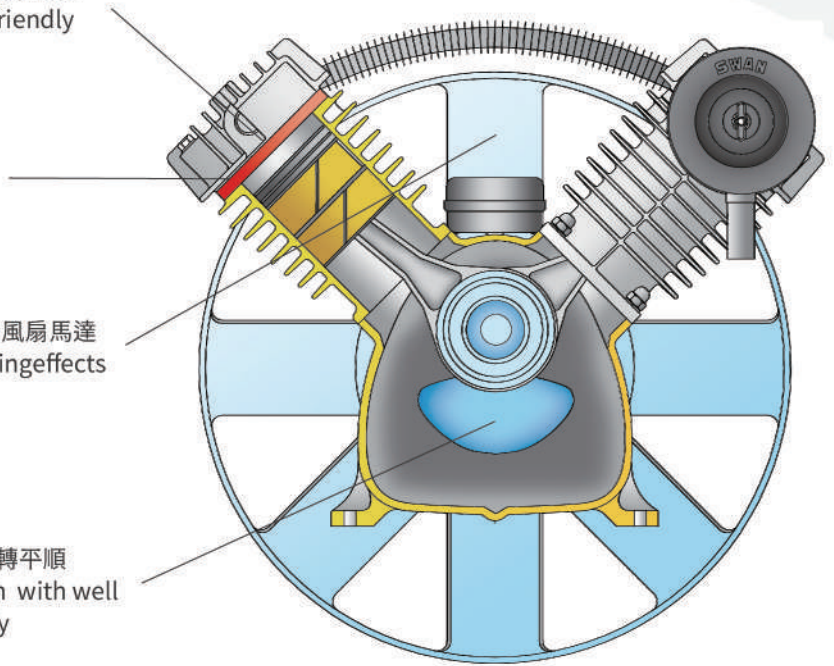

鋁合金汽缸

Aluminum Alloy Cylinder

表面經硬膜處理，散熱、耐磨耗性佳

Aluminum alloy cylinder: the cylinder be covered with special treatment to ensure good heat dissipation, wear resistance and smooth running



壓縮環組

Compression Ring Set

自潤性與耐磨性的PTFE特殊材質，耐磨耗性佳

Compression ring group: with self-lubricating and anti-friction material to ensure smooth and long-last running



連桿與軸承組

Combine Connecting Rod and Bearings

採用特殊油脂軸承使零件壽命增長

With special grease for bearing lubrication to ensure its long service life

箱型靜音空壓機

Cabinet Silent Air Compressor



SDU-205CD



SDU-203C-1



特性 Features

01

- 靜音運作，高流量空氣冷卻系統，提升運轉效率
- 節能電子控制系統，提供潔淨無油的空氣氣源
- 大型風扇、散熱快，經濟耐用、壽命長
- 全半自動、真方便
- Silent operation, High capacity cooling air system for performance improving
- Energy-saving electronic control system. Provide clean and oil-less compressed air
- Better cooling effects by enlarged cooling fan
More durable and economic for long-life operation
- User-friendly dual control system

02

SDU-C/SDU-CD系列，無油潔淨的空氣品質，加上高效能噪音阻絕設計、結實的框架式結構，帶給您潔淨又安靜的雙重優質體驗。運轉安靜、佔地小、簡易操作、維護容易。

SDU-C/SDU-CD series air compressors provide oil-less & dirt-free purified compressed air to meet your needs. The sturdy frame-structured enclosed cover is featured with high-efficient cooling air circulating system and noise-proof material to substantially reduce the noise & vibration in operation, and provide quiet working environment. The dependable oil-less silent model will deliver clean air and greatly reduce the noise level. In addition, the compact design, and user friendly interface, combined with the optimized controller can monitor the working status and improve its reliability.



箱型靜音空壓機

Cabinet Silent Air Compressor



SDU-415C-1

SDU-430CD

Specs. 規格 Model 型式	Motor (kw/hp) 馬 達	Working Pressure (kg/cm ² .g) 使用壓力	F.A.D. (l/min) 實際排氣量	Noise Level (dB) 噪音值	Dimension LxWxH (mm) 尺 寸	Weight (kg) 重 量
SDU-203C-1	2.2 3	8	285	70	850X730X1280	195
SDU-205C-1	3.7 5	8	485	70	850X730X1280	210
SDU-307C-1	5.5 7.5	8	730	73	960X830X1460	315
SDU-310C-1	7.5 10	8	885	73	960X830X1460	330
SDU-415C-1	11 15	8	1225	75	1000X970X1360	539

Specs. 規格 Model 型式	Motor (kw/hp) 馬 達	Working Pressure (kg/cm ² .g) 使用壓力	F.A.D. (l/min) 實際排氣量	Noise Level (dB) 噪音值	Air Fiter 過濾器	Dimension LxWxH (mm) 尺 寸	Weight (kg) 重 量
SDU-205CD	3.7 5	8	451	65	ARB ARA	850x730x1470	330
SDU-310CD	7.5 10	8	793	70	ARB ARA	960x830x1470	366
SDU-415CD	11 15	8	1225	75	ARB ARA	1000x970x1780	660
SDU-430CD	11X2 15X2	8	1225X2	75	ARB ARA	1830x970x1700	1196

※本公司不斷研究改進，規格數據若有變更，恕不另行通知。

※如有規格外之壓力、馬力、排氣量等其他需求，歡迎您與本公司洽詢！

※Reserve the right to alter design or specifications. Due to time lag, actual specification may differ from that shown above.

※Other specific requirement about working pressure, horsepower, air delivery, etc. are available upon request.

結構 Structure

STABILITY



無油優勢 Oil-less Advantage

採用高信賴精密零組件，提供穩定的產品壽命；乾式運轉設計結構不使用潤滑油，避免油氣汙染製程設備與產品，能以更低的處理成本來達成高品質潔淨空氣需求。 High reliability precision components to provide stable product life; Dry running design structure does not use lubricant, avoiding the pollution of oil mist on equipment and products, to lower the processing cost to achieve high quality clean air demand.



後部冷卻器 After Cooler

高效能後部冷卻器和大冷卻風扇系統，有效降低空氣出口與運轉機體溫度。 After-cooler and big cooling fan system effectively reduce the temperature of the air outlet and the operating bare pump.

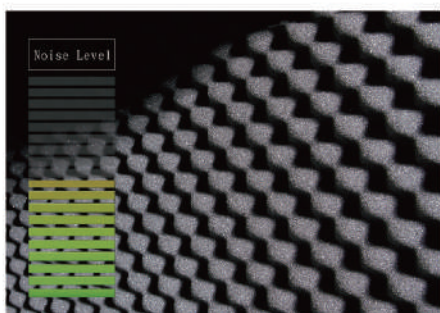

噪音阻絕設計 Noise Blocking Design

採用結實板金結構與吸音棉與高效能防音設計，有效降低運轉噪音和震動。 Adopt strong sheet metal structure, sound-absorbing cotton and sound proof design to reduce running noise and vibration effectively.



緩衝避震器 Cushion Shock-absorber

防震效率佳，有效減緩運轉噪音。結構堅固，耐受性佳，使用壽命長。 Effectively reduce the running noise, and the anti-vibration efficiency is good. Sturdy structure, good weather resistance and long service life.



內建乾燥機及過濾器 (僅SDU-CD系列機型)

Air Dryer & Filters Built In (only SDU-CD series)

整機結合乾燥機與過濾器，使無油空氣更加乾燥及潔淨。 SDU-CD series are equipped with refrigerated air dryer and filters to provide superior clean and dry air.

單機雙機空壓機

Simplex/Duplex Air Compressor



SDT-415

SDS-415

GP-510



結構 Structure

無油優勢 Oil-less Advantage

採用高信賴精密零組件，提供穩定的產品壽命；乾式運轉設計結構不使用潤滑油，避免油氣汙染製程設備與產品，能以更低的處理成本來達成高品質潔淨空氣需求。

High reliability precision components to provide stable product life; Dry running design structure does not use lubricant, avoiding the pollution of oil mist on equipment and products, to lower the processing cost to achieve high quality clean air demand.

後部冷卻器 After Cooler

效能佳的後部冷卻器及大冷卻風扇系統，有效降低空氣出口溫度。

With excellent performance of the after cooler and a large cooling fan to effectively reduce the outlet temperature.

皮帶調整機構 Belt Tension Mechanism

皮帶張力調整容易，日常維護簡易確實。

Easy to adjust the belt's tension for easy and simple routine maintenance.

Specs. 規格 Model 型式	Motor (kw/hp) 馬 達		Working Pressure (kg/cm ² .g) 使用 壓力	F.A.D. (l/min) 實際排氣量	Tank Capacity (liter) 儲氣桶容量	Dimension LxWxH (mm) 尺 寸	Weight (kg) 重 量
GP-510	3.7	5	8	485	165	1440X1230X1400	400

Specs. 規格 Model 型式	Motor (kw/hp) 馬 達		Working Pressure (kg/cm ² .g) 使用 壓力	F.A.D. (l/min) 實際排氣量	Dimension LxWxH (mm) 尺 寸	Weight (kg) 重 量
SDS-205	3.7	5	8	485	950X880X1150	200
SDS-310	7.5	10	8	885	880X710X1305	305
SDS-415	11	15	8	1225	935X730X1330	415
SDT-205	3.7X2	5X2	8	970	1780X620X1150	435
SDT-310	7.5X2	10X2	8	1770	1910X710X1330	615
SDT-415	11X2	15X2	8	2450	2050X800X1300	883

※本公司不斷研究改進，規格數據若有變更，恕不另行通知。

※如有規格外之壓力、馬力、排氣量等其他需求，歡迎您與本公司洽詢！

※Reserve the right to alter design or specifications. Due to time lag, actual specification may differ from that shown above.

※Other specific requirement about working pressure, horsepower, air delivery, etc. are available upon request.

壓縮機機體

Oil-less Compressor Pump



SDU(P)-310N

結構 Structure

01 / 單段壓縮設計 Single Stage Design

- 壓力10 kg/cm²，單段壓縮設計
- 高效能冷卻系統
- Single stage with pressure up to 10 kg/cm²
- High efficient cooling system

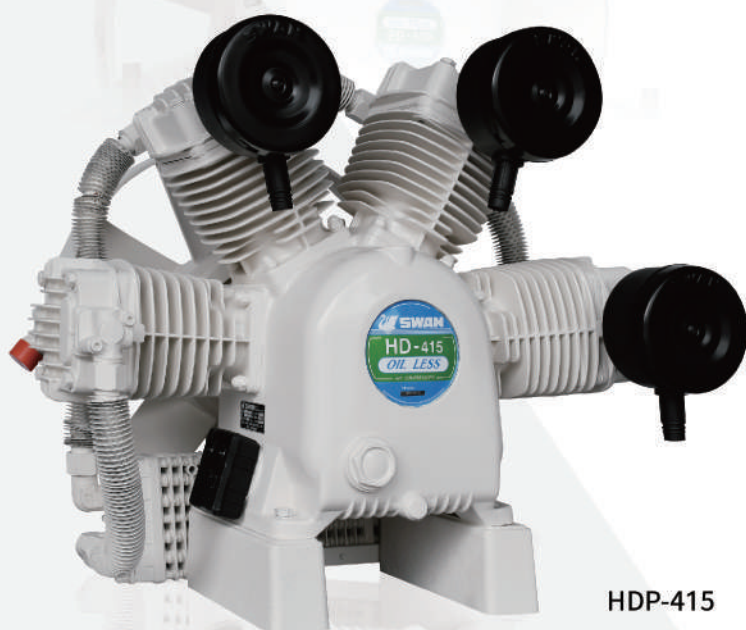

HDP-415

02 / 雙段壓縮設計 Two Stage Design

- 壓力12 kg/cm²，雙段壓縮設計
- 高效能冷卻系統，大風量風扇、高效率冷卻系統
- Two stage design with working pressure up to 12 kg/cm²
- High efficient cooling system

無油式空壓機機體

Oil-less Air Compressor Pump

- 無油式空壓機，提供100%清淨無油的壓縮空氣。高效率冷卻系統組件，適合重負載連續運轉。
- 高效率中間冷卻器及後部冷卻器，有效降低排氣溫度。高效率、高壽命。高強度、高精度、高信賴度的零組件設計。
- Oil-less air compressors provide 100% pure oil-less compressed air. High efficiency cooling system components for heavy-duty continuous operation.
- High efficiency inter-cooler and after-cooler (option) will reduce the temperature of compressed air.

Specs. 規格 Model 型式	Motor (kw/hp) 馬 達		Working Pressure (kg/cm ² .g) 使用 壓力	F.A.D. (l/min) 實際排氣量	Dimension LxWxH (mm) 尺 寸	Weight (kg) 重 量
SDU(P)-203	2.2	3	8	285	1480X520X950	52
SDU(P)-205	3.7	5	8	485	1525X580X1200	71
SDU(P)-307	5.5	7.5	8	730	1835X650X1300	90
SDU(P)-310	7.5	10	8	885	1835X650X1300	90
SDU(P)-415	11	15	8	1320	1835X650X1300	105
SDU-420	15	20	8	1635	1143x799x826	321
SDU-425	18	25	8	2037	1143x799x826	321
SDU-430	25	30	8	2495	1143x799x826	321

Specs. 規格 Model 型式	Motor (kw/hp) 馬 達		Working Pressure (kg/cm ² .g) 使用 壓力	F.A.D. (l/min) 實際排氣量	Dimension LxWxH (mm) 尺 寸	Weight (kg) 重 量
SDU(P)-205N	3.7	5	10	427	625x460x600	71
SDU(P)-310N	7.5	10	10	799	720x520x690	90
SDU(P)-415N	11	15	10	1056	810X560X700	105
HDP-205	3.7	5	12	389	610x460x585	89
HDP-310	7.5	10	12	834	702x515x680	113
HDP-415	11	15	12	1250	769x538x666	142
HDU-420	15	20	12	1540	1088x883x826	355
HDU-425	18	25	12	1849	1088x883x826	355
HDU-430	25	30	12	2211	1088x883x826	355

※本公司不斷研究改進，規格數據若有變更，恕不另行通知。

※如有規格外之壓力、馬力、排氣量等其他需求，歡迎您與本公司洽詢！

※Reserve the right to alter design or specifications. Due to time lag, actual specification may differ from that shown above.

※Other specific requirement about working pressure, horsepower, air delivery, etc. are available upon request.





東正鐵工廠 股份有限公司

TONG CHENG IRON WORKS CO., LTD.

No. 16, Sec. 2, Ta Chin Street, South Dist., Taichung 402026, Taiwan

公 司：402026 台中市南區大慶街二段16號

TEL:+886-4-2261-2135 FAX:+886-4-2262-8246/+886-4-2261-5465

www.swan-aircompressor.com